

### INPUT SECTION

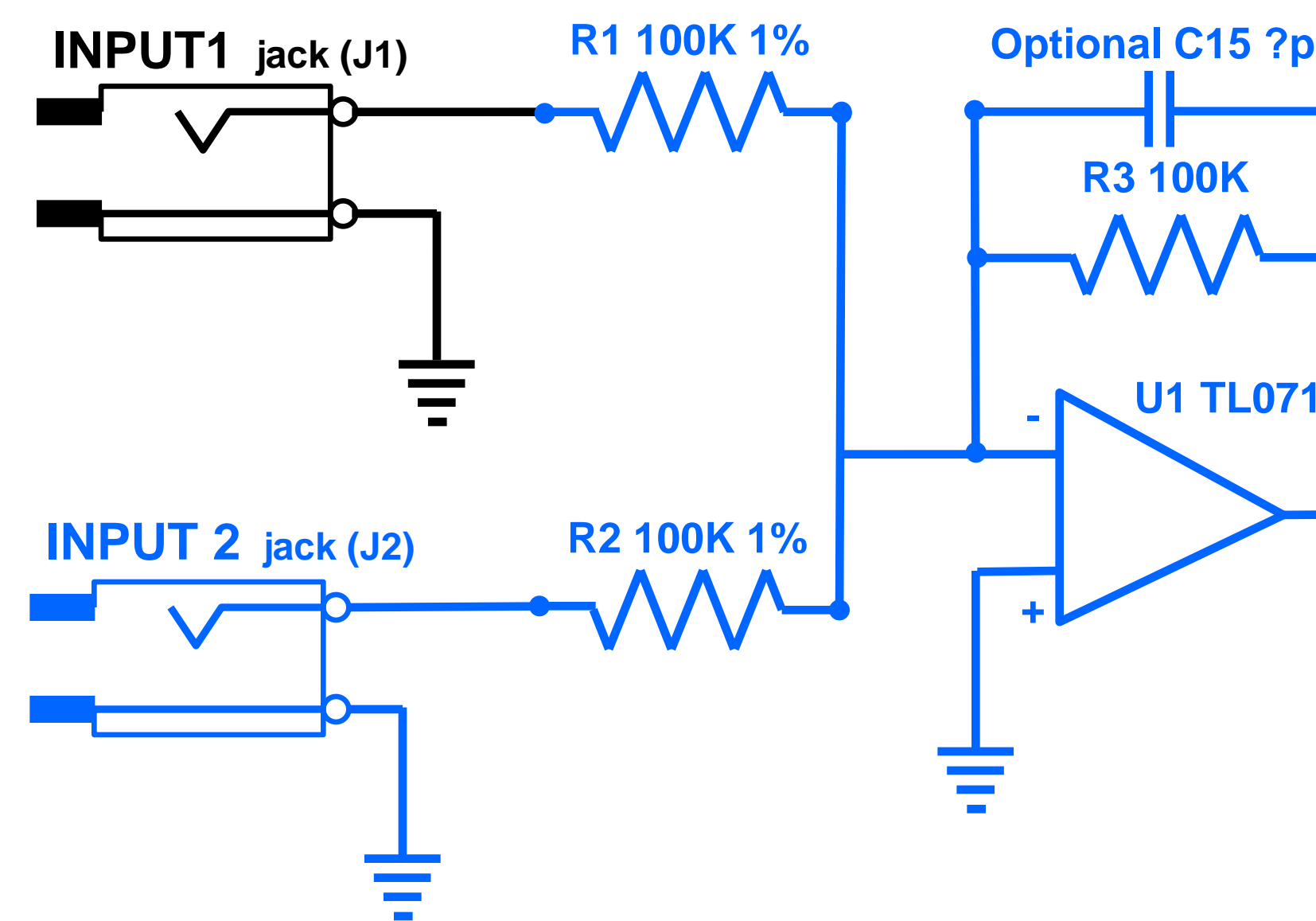

### "OFFSET" SECTION

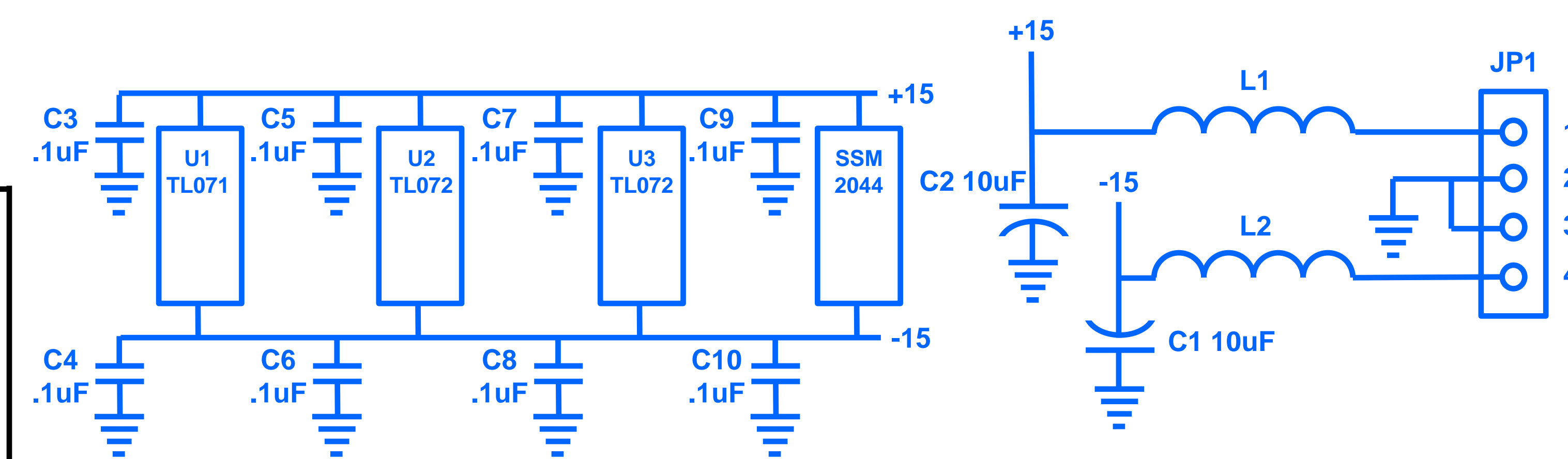
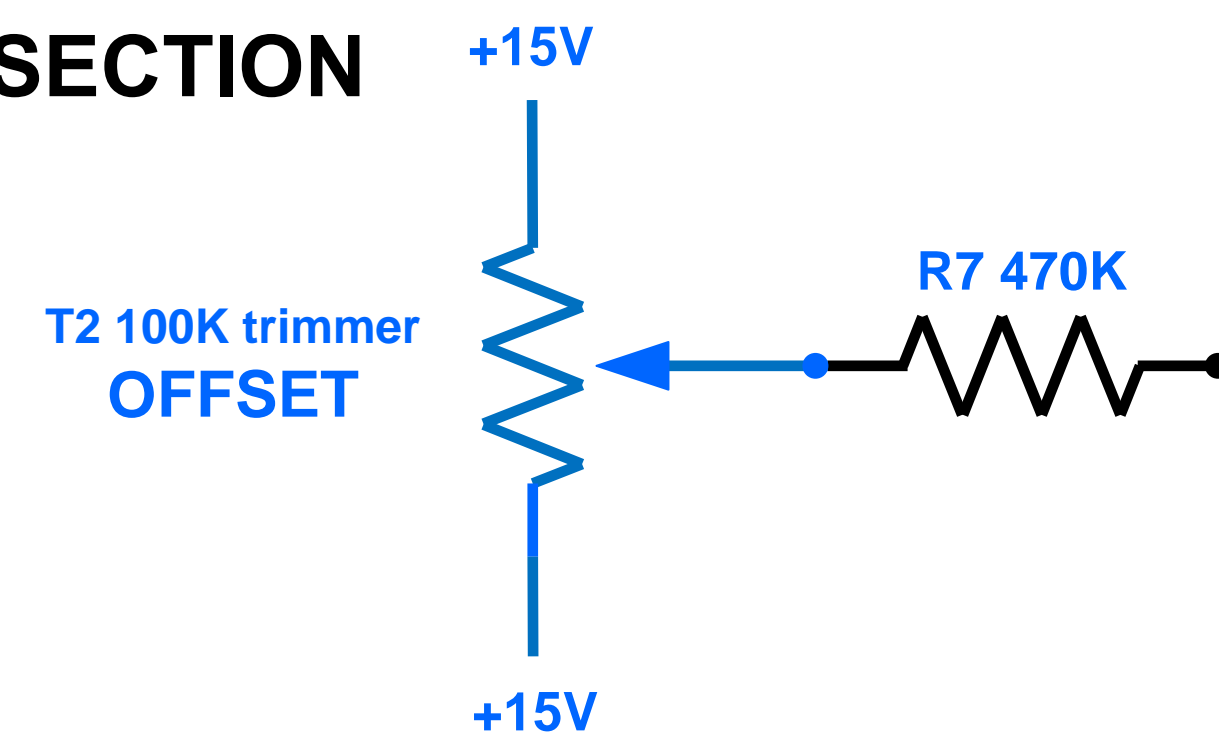

### CONTROL SECTION

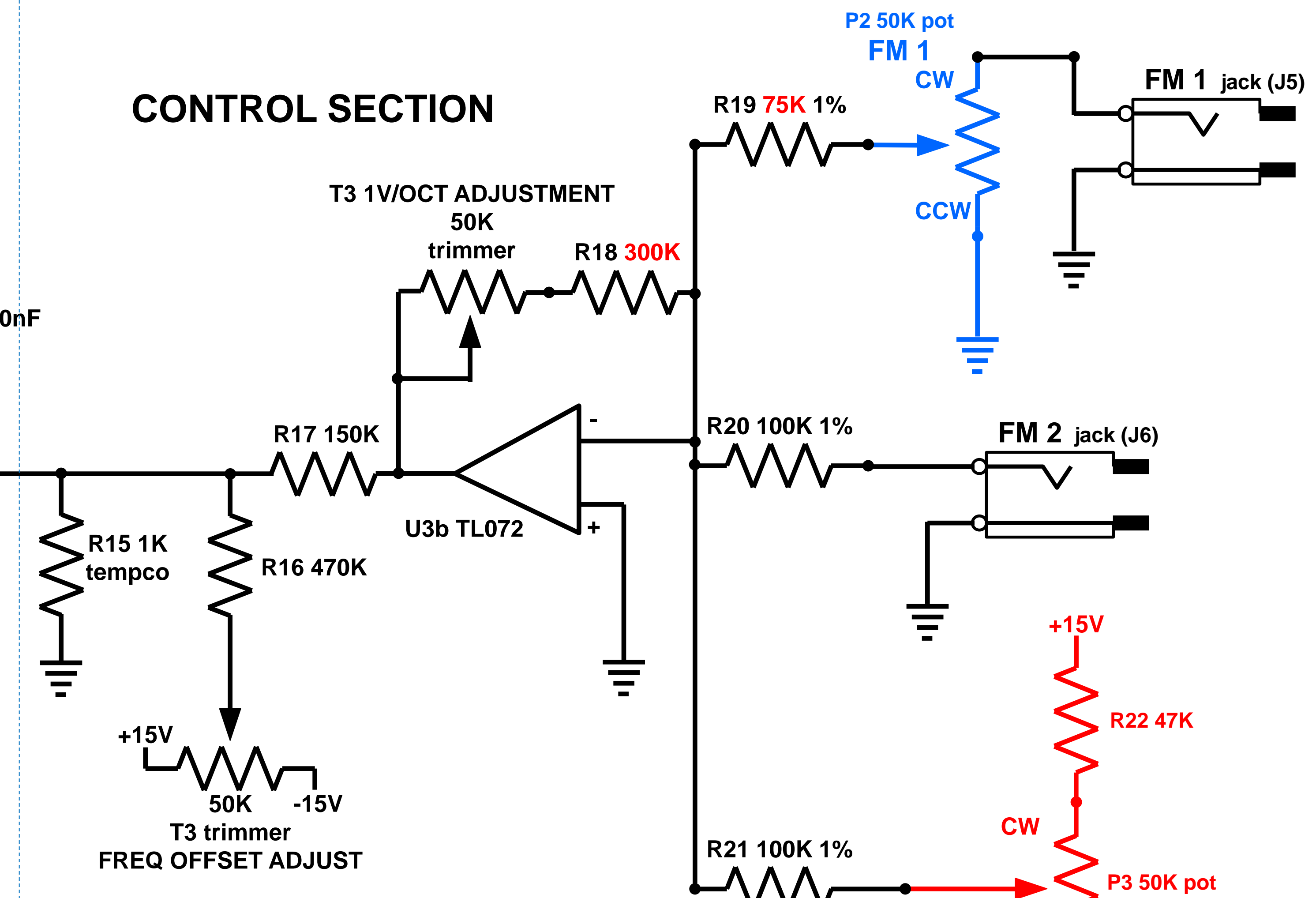

### RESONANCE SECTION

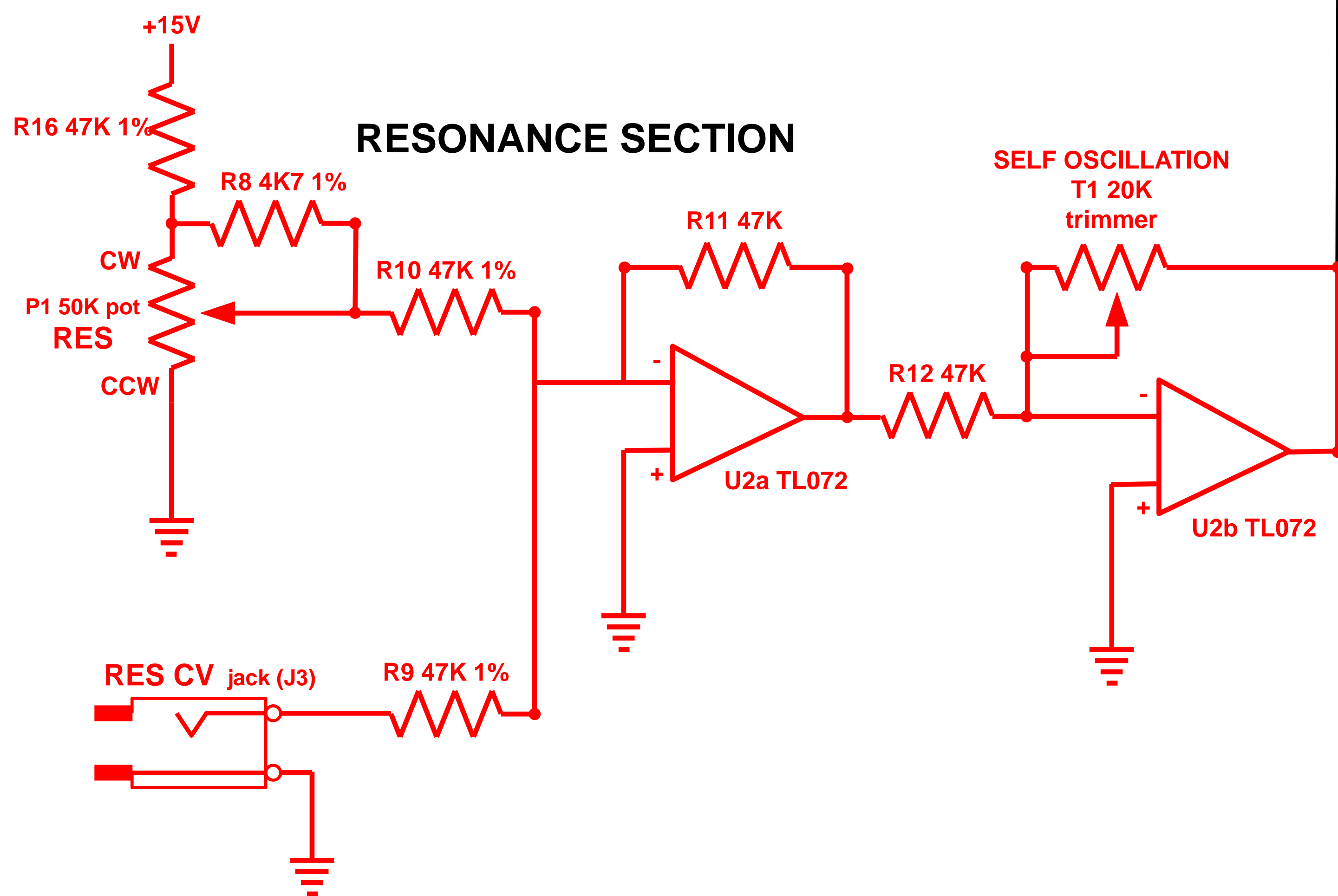

### OUTPUT SECTION

